



# Modular Cooking Range Line e-XP 900 Pasta Cooker 2x40 Liters Auto Refill 800mm

ITEM # \_\_\_\_\_

MODEL # \_\_\_\_\_

NAME # \_\_\_\_\_

SIS # \_\_\_\_\_

AIA # \_\_\_\_\_



**391663 (E90OCDBAMEV)** e-XP Auto-refill Pasta Cooker, 40+40-lt, electric, 2 wells

## Short Form Specification

**Item No.** \_\_\_\_\_

The Auto-refill Pasta Cooker is engineered for performance, efficiency, and ease of use and maintenance. Featuring two 40 L water basins seamlessly welded into the 2 mm stainless-steel worktop. A large digital display shows power settings and operational status, while the standby mode ensures energy efficiency and rapid recovery. Automatic refill keeps the optimal water level, ensuring consistent results and productivity. Equipped with infrared heating system beneath the well, the pasta cooker offers consistent performance. All major components are front-accessible, with right-angled side edges for flush alignment between units and rounded corners for easy cleaning. Constructed with AISI 316-L stainless steel for the basin and Scotch Brite-finished AISI 304 exterior panels, the unit includes height-adjustable feet and IPX4 water protection. The large manual ball-valve drain enables fast emptying while the automatic low-water shut-off prevents overheating. Two-speed water refill regulated by water level sensor at maximum or minimum water flow intensity. As optional accessories can be included Automatic Lifting System (200 mm module with three GN 1/3 basket supports, up to six small baskets, programmable for nine cooking times) and the Energy Saving Device (ESD), which pre-heats incoming water up to 60 °C using recovered overflow heat.

## Main Features

- Automatic lifting system (optional accessory): 200mm wide unit with three stainless steel basket supports, holding one GN 1/3 basket each, to be placed on either or both sides of machine to provide automatic lifting for six small portion baskets (t)
- Large visible digital display showing power settings, on/off status of the appliance and on/off status of the heating elements.
- 40 liters water basin.
- All major compartments located in front of unit for ease of maintenance.
- Automatic refill keeps the optimal water level, ensuring consistent results and uninterrupted productivity.
- Two-speed water refill regulated by water level sensor at maximum or minimum water flow intensity.
- Automatic low-water level shut-off: no accidental over-heating.
- In addition to cooking pasta, the appliance can be used for noodles of every kind, rice, dumplings and vegetables.
- Large drain with manual ball-valve for fast emptying of well.
- Provided with integrated drip zone on which baskets can be placed for draining purposes.
- Unit to be mounted on height adjustable feet in stainless steel.
- Unit to have infrared heating system positioned beneath the base of the well.
- Unit to feature skimming zone for starch removal: improved water quality over time.

## Construction

- All exterior panels in Stainless Steel with Scotch Brite finishing.
- Model has right-angled side edges to allow flush fitting joints between units, eliminating gaps and possible dirt traps.
- One piece pressed 2 mm work top in Stainless steel.
- Water basin in 316-L type Stainless steel.
- Water basin is seamlessly welded into the top of the appliance.
- Unit is 930 mm deep to give a larger working surface area.
- 2 separate wells for versatile cooking.
- IPX5 water resistance certification.

## Sustainability

- ESD available as accessory (installed separately): energy saving device uses heat produced by water drained through the overflow to pre-heat tap-in water up to 60°C, for constant water boiling.
- Standby function for energy saving and fast recovery of maximum power.



APPROVAL: \_\_\_\_\_



#### Included Accessories

- 2 of Door for open base cupboard PNC 206350

#### Optional Accessories

- Junction sealing kit PNC 206086
- 4 wheels, 2 swivelling with brake (700/900XP). It is mandatory to install with base supports for feet/wheels. PNC 206135
- Flanged feet kit PNC 206136
- Frontal kicking strip for concrete installation, 800mm PNC 206148
- Frontal kicking strip for concrete installation, 1000mm PNC 206150
- Frontal kicking strip for concrete installation, 1200mm PNC 206151
- Frontal kicking strip for concrete installation, 1600mm PNC 206152
- 2 SIDE KICKING STRIPS-CONCRETE INST-900 PNC 206157
- Frontal kicking strip, 800mm (not for refr-freezer base) PNC 206176
- Frontal kicking strip, 1000mm (not for refr-freezer base) PNC 206177
- Frontal kicking strip, 1200mm (not for refr-freezer base) PNC 206178
- Frontal kicking strip, 1600mm (not for refr-freezer base) PNC 206179
- Pair of side kicking strips (not for refr-freezer base) PNC 206180
- 2 panels for service duct for single installation PNC 206181
- Lid and lid holder for 40lt pasta cookers PNC 206190
- 2 panels for service duct for back to back installation PNC 206202
- 4 feet for concrete installation PNC 206210
- Set of ergonomic baskets for 40lt pasta cookers PNC 206233
- 1 ERGONOMIC BASKET FOR 40L PASTA COOKER PNC 206237
- False bottom for 40lt pasta cooker square baskets PNC 206238
- Chimney upstand, 800mm PNC 206304
- BACK HANDRAIL 800 MM - MARINE PNC 206308
- BACK HANDRAIL 1200 MM - MARINE PNC 206309
- Energy saving device for pasta cookers PNC 206344
- Door for open base cupboard PNC 206350
- Automatic programmable basket lifting system for 40lt pasta cookers, 3 lifters PNC 206353
- Base support for wheels (lateral) for 23lt fryers and pastacookers (900) PNC 206372
- Rear paneling - 800mm (700/900) PNC 206374
- Rear paneling - 1000mm (700/900) PNC 206375
- Rear paneling - 1200mm (700/900) PNC 206376
- FRAME-2 PASTACOOK.BASKET(900-AUTO.LIFT) PNC 206395
- Chimney grid net, 400mm PNC 206400
- 2BASKETS SQR L+R FOR 40L PASTA COOKER PNC 206433
- Side handrail-right/left hand PNC 216044
- Frontal handrail 800mm PNC 216047
- Frontal handrail 1200mm PNC 216049

- Frontal handrail 1600mm PNC 216050
- 2 side covering panels for free standing appliances PNC 216134
- Large handrail - portioning shelf, 800mm PNC 216186
- 3x1/3GN baskets for 40lt pasta cookers PNC 927210
- 2x1/2GN baskets for 40lt pasta cookers PNC 927211
- 3 round baskets diam. 181mm for 40lt pasta cookers (927219 must be ordered together) PNC 927212
- 6 round baskets for 40-It pasta cookers (927219 must be ordered together) PNC 927213
- 1x1/1GN basket for 40lt pasta cookers PNC 927216
- Grid support for 40lt pasta cooker round baskets PNC 927219
- Upper support frame to hold 6 round baskets for 40lt pasta cookers (alternative to 927219 for 6 round baskets) PNC 960644

Front

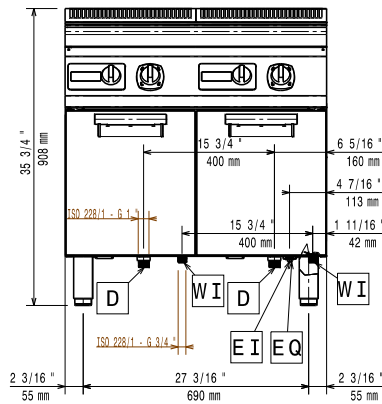

Side

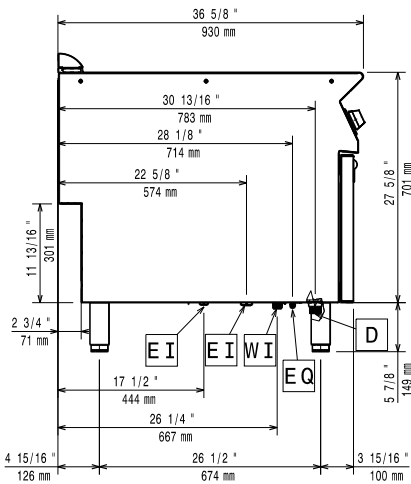

- D = Drain
- EI = Electrical inlet (power)
- EQ = Equipotential screw
- WI = Water inlet

Top

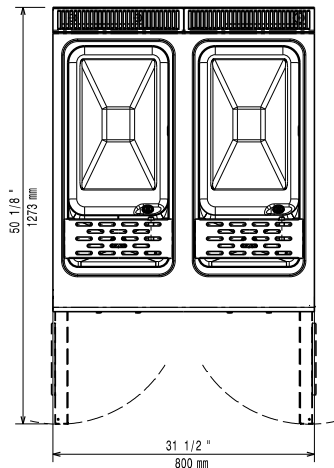

#### Electric

Supply voltage:	380-400 V/3N ph/50-60 Hz
Electrical power max.:	20 kW
Total Watts:	20 kW

#### Water:

Drain "D":	1"
Incoming Cold/hot Water line size:	3/4"

#### Key Information:

Usable well dimensions (width):	305 mm
Usable well dimensions (height):	315 mm
Usable well dimensions (depth):	515 mm
Well Capacity (MAX):	40 lt MAX
External dimensions, Width:	800 mm
External dimensions, Depth:	930 mm
External dimensions, Height:	850 mm
Net weight:	79 kg
Shipping weight:	93 kg
Shipping height:	1090 mm
Shipping width:	1020 mm
Shipping depth:	880 mm
Shipping volume:	0.98 m <sup>3</sup>
Certification group:	eXPEPC92